

XVII. THE BAKERIAN LECTURE.—*On the Photographic Method of Mapping the least Refrangible End of the Solar Spectrum.*

*By Captain W. DE W. ABNEY, R.E., F.R.S.*

Received December 17, 1879,—Read January 8, 1880.

[PLATES 30–32.]

THE research which I commenced some five years ago on a method of photography by which the least refrangible end of the solar spectrum could be mapped has reached such a stage that it seems desirable that I should put on record the results I have obtained, and with it to present a map of the solar spectrum between wave lengths 7600 and 10,750 based upon measurements from a series of photographs which appear to be satisfactory for the purpose.

*Action of dyes on silver bromide.*

In December, 1873,\* Dr. H. C. VOGEL, of Berlin, announced that by means of dyed collodion films which contained silver bromide he had been enabled to photograph with the yellow and green rays of the solar spectrum, which had hitherto been supposed to be possessed of but little chemical effect. About the same time I had set myself the task of mapping the ultra-red region of the spectrum, and I was naturally led to examine the method advocated by Dr. H. C. VOGEL.

If a spectrum be thrown on an ordinarily prepared photographic plate containing only silver bromide, it is well known that the length of the spectrum impressed varies considerably from that obtained by a plate containing silver iodide or silver bromo-iodide. The commencement of the photographic action in the first case is somewhere near the line B or slightly below, and in the last two near E in the green; in all the three the action extends to the limit of the solar spectrum in the ultra-violet. The relative chemical effects produced by the different rays show themselves by a varying thickness, or what is usually called density, of the metallic silver reduced or precipitated by the action of developing solutions. For the above-named silver compounds the maximum effect is somewhere about the line G; and if we represent the density of the metallic silver at any point by ordinates, it will be found that the area of the curve

\* Photographic News, Dec. 12, 1874.

formed by joining the ordinates fairly represents the relative sensitiveness of the compound to the action of white light.

With silver bromide the curve falls gradually towards B, and similarly towards the ultra-violet. With silver iodide and bromo-iodide the curve falls suddenly near G, and the chemical effect from the bottom of this descent to E is but very feeble; whilst for the more refrangible end above G it follows pretty nearly the curve of the bromide.

When collodion films containing silver bromide are dyed, by flowing over them an alcoholic or aqueous solution of certain dyes, and exposed to the spectrum, the resulting curves are modified in a marked manner. They almost exactly correspond to curves compounded of the absorption curve of the dye used and of the absorption curve of the unreduced silver bromide. For example, if we examine a simple bromide film with the spectroscope, it will be seen that an absorption takes place along the whole visible spectrum corresponding with the density curve of this compound. An examination of the spectrum of eosine, supposing we are going to employ that dye to stain the film, gives an absorption band in the green, together with a less marked region of absorption in the blue and violet. If these two absorption curves be combined, we shall find that in the density curve obtained by exposing a stained film to the action of the spectrum we get a reproduction of this compound curve. VOGEL explained this remarkable action by a theory which seemed to be contrary to our present idea of molecular physics; and in my experiments conducted in this direction I had the good fortune to arrive at a more acceptable solution, involving no new laws of the action of radiation on matter. Some of the dyes employed (and most, if not all, of these belonged to the aniline series) could form compounds with silver, and when brought in contact with silver nitrate the action of light on the compounds was perfectly intelligible. VOGEL, however, pointed out that if a bromide film were perfectly freed from all silver nitrate by immersion in potassium bromide, then washed, next treated with tannin, and dyed, a similar density curve was obtained. I need scarcely recount the numerous experiments which I undertook; one of the final ones will be sufficient to show how a reasonable explanation could be offered.

A few granules of the dye were taken and dissolved in normal collodion, a glass plate was coated in the ordinary manner, and the film dried and exposed to the spectrum. It was found that in those regions where the spectrum was absorbed a bleaching of the dyed film was evident. Thus, with eosine a bleaching took place in the green rays corresponding with its absorption band, and to a lesser degree in the yellow and blue rays. If after such an exposure the dyed collodion were coated in the dark room with collodion containing silver bromide in suspension, and an alkaline developing solution applied, it was found that the silver bromide was reduced to metallic silver on those parts of the plate which had been bleached by the action of the spectrum, and the density curve followed the curve of absorption of the dye.

Photographers have been long aware of the fact that some sorts of organic matter on a glass plate will cause the reduction of silver on those portions of the plate on

which it exists. The bleached dyes partake of the nature of this organic matter, and we are forced to conclude that a state of oxidation favours this disposition. From exposure of the dyes in different media to the action of the spectrum it seems that the bleaching is due to a state of oxidation of the dye. If a film containing silver bromide, and dyed, were exposed in hydrogen to the action of the spectrum, the density curve was that due alone to the action of silver bromide, and the dye did not affect it, excepting so far as it acted as a screen to prevent the full intensity of the light falling on the bromide.

The dyes which are most active are those which are known as yielding fugitive colours; a permanent colour produces no effect beyond the above screening the light from the silver bromide. It should be remarked that when a film containing finely-suspended matter is dyed the change effected on the dye is much more rapid than when a continuous film is acted upon, for the dye surrounds these very small particles, and thus a large surface of it is exposed to the air, and renders oxidation comparatively easy. As a result of these experiments I can confidently state that in no case did the addition of the dye cause any chemical effect to be produced by the rays below A of the solar spectrum, nor has VOGEL claimed that they do. I am aware that in the Proceedings of the Royal Society\* Major WATERHOUSE has stated that by staining the film with turmeric he obtained evidence of the existence of lines in the solar spectrum a little less refrangible than A, but it must be observed that the lines so shown are, except in one instance, "reversed." That is, absorption lines appear as opaque on the transparent body of the spectrum instead as of a normal character, viz.: transparent on an opaque body. This reversal is a matter to which I have referred in the Proceedings of the Royal Society,† and is dependent on a different action entirely to that which I am now considering.

*Preparation of a film sensitive to the infra-red region.*

My earliest endeavours were directed to extending this action of organic matter, so that sensitiveness of the compound might be obtained in the ultra-red regions. By weighting the molecules of the silver bromide with gum resins, the spectrum was impressed considerably below A and the absorption lines were unreversed. Measures of the heating effect of the solar spectrum on lampblack, as shown by the thermo-pile and Sir J. HERSCHEL'S well-known researches, showed that the lower limit of the prismatic spectrum had not been reached; it therefore seemed advisable to search in a different direction for a more sensitive compound. The salts of silver still seemed the most feasible to work with, and more especially the bromide, and efforts were made to obtain this compound in a different molecular condition to that generally found. I need not detail the different methods of preparation of this compound in collodion that were carried out. In some cases I obtained it in a state which when viewed in a

\* Vol. xxiv., p. 186.

† Vol. xxvii., pp. 291 and 451.

film by transmitted light appeared of a sky-blue colour, inclining to a green tint, visibly absorbing the red. In this condition it was sensitive to the whole spectrum, visible and invisible. There was much uncertainty attaching to the preparation; about one batch of the salt suspended in collodion out of five or six fulfilling the requisite conditions. I am now, however, in a position to prepare it without any risk of failure, my experiments of the last nine months having showed the conditions absolutely necessary for success. The following is the mode of preparation. A normal collodion is first made according to the formula below:—

Pyroxyline (any ordinary kind) . . . . .	16 grains
Ether (.725 Sp.) . . . . .	4 oz.
Alcohol (.820) . . . . .	2 oz.

This is mixed some days before it is required for use, and any undissolved particles are allowed to settle, and the top portion is decanted off. 320 grains of pure zinc bromide are dissolved in  $\frac{1}{2}$  oz. to 1 oz. of alcohol (.820) together with 1 drachm of nitric acid. This is added to 3 ozs. of the above normal collodion, which is subsequently filtered. 500 grains of silver nitrate are next dissolved in the smallest quantity of hot distilled water, and 1 oz. of boiling alcohol .820 added. This solution is gradually poured into the bromized collodion, stirring briskly whilst the addition is being made. Silver bromide is now suspended in a fine state of division in the collodion, and if a drop of the fluid be examined by transmitted light it will be found to be of an orange colour.

Besides the suspended silver bromide, the collodion contains zinc nitrate, a little silver nitrate, and nitric acid, and these have to be eliminated. The collodion emulsion is turned out into a glass flask, and the solvents carefully distilled over with the aid of a water bath, stopping the operation when the whole solids deposit at the bottom of the flask. Any liquid remaining is carefully drained off, and the flask filled with distilled water. After remaining a quarter-of-an-hour the contents of the flask are poured into a well-washed linen bag, and the solids squeezed as dry as possible. The bag with the solids is again immersed in water, all lumps being crushed previously, and after half-an-hour the squeezing is repeated. This operation is continued till the wash water contains no trace of acid when tested by litmus paper. The squeezed solids are then immersed in alcohol .820 for half-an-hour to eliminate almost every trace of water, when after wringing out as much of the alcohol as possible the contents of the bag are transferred to a bottle, and 2 ozs. of ether (.720) and 2 ozs. of alcohol (.805) are added. This dissolves the pyroxyline and leaves an emulsion of silver bromide, which when viewed in a film is essentially blue by transmitted light.

All these operations must be conducted in very weak red light—such a light, for instance, as is thrown by a candle shaded by ruby glass,\* at a distance of 20 feet. It

\* If a green light of the refrangibility of about half way between E and D could be obtained it would be better than the faint red light transmitted by ruby glass, since the bromide is less sensitive to it than to the latter.

is most important that the final washing should be conducted almost in darkness. It is also essential to eliminate all traces of nitric acid, as it retards the action of light on the bromide, and may destroy it if present in any appreciable quantities. To prepare the plate with this silver bromide emulsion all that is necessary is to pour it over a clean glass plate, as in ordinary photographic processes, and to allow it to dry in a dark cupboard.\*

For development after exposure I recommend what is known as the ferrous oxalate developer. This is prepared by dissolving ferrous oxalate in a saturated solution of neutral potassium oxalate, adding the iron salt till no more is taken up. To make up the developing solution, equal parts of this solution of ferrous oxalate and of a solution of potassium bromide, 20 grains to the ounce, are employed. This mixture is placed in a clean developing glass just before development is to take place. The film is first softened by flowing over it a mixture of equal parts of alcohol and water, and is then well washed. The developer is now poured over the plate, taking care to keep the fingers from touching any part of the film. The image will appear gradually, and should have fair density when all action is exhausted.

The intensity can be materially increased by using the ordinary intensifying solutions of pyrogallol, citric acid, and silver nitrate. The unreduced silver bromide is removed by a saturated solution of sodium thiosulphite in water, from all traces of which the film should be thoroughly washed before being allowed to dry.†

The operation of development should take place in a very subdued red light, that recommended for the preparation of the emulsion being the safest.‡ It is, however, somewhat remarkable that when the developing action has once been set up a greater quantity of light may be admitted to fall on the plate than before the action commences. The bromide of potassium probably prevents any further action by the light, which may account for it. It should be noted that the image may be developed by the ordinary alkaline method, though not so satisfactorily, a slight veil being usually apparent.

I may here state that by diminishing the amount of nitric acid to one-fourth the amount given in the preparation of the emulsion, it is possible in very cold weather to obtain plates which are sensitive to very low radiations, such as the radiations proceeding from boiling mercury or even boiling water. In summer-time this emulsion, as would naturally be expected, produces what are known as "foggy pictures;" but it can be rendered of use by flooding with hydrochloric acid (see note). In the prepara-

\* It has been found advantageous to coat the plate in red light, and then to wash the plate and immerse it in a dilute solution of HCl, and again wash, and finally dry. These last operations can be done in dishes in absolute darkness; the hydrochloric acid gets rid of any silver sub-bromide which may have been formed by the action of the red light.

† It aids cleanness of the film if, before drying, a solution of HCl in water (one to three) is poured over it, and afterwards eliminated by washing. This removes any calcium oxalate that may be formed in the film.

‡ It can be developed in absolute darkness by using dishes for each operation.

tion of such an emulsion the water bath must be kept at a temperature but little above that of the boiling point of ether.

*Apparatus employed.*

One of the objects I have had in view was to compare the spectra obtained by this photographic method with the thermographs obtained by Sir JOHN HERSCHEL, and also with the energy curves obtained by means of the thermopile. To do this it seemed necessary to work under the same conditions as those under which these results were obtained, and I attempted to do so. After many experiments, however, I found that the absorption lines lay so close together when the beam of light was sent through one prism that I have employed three prisms to obtain greater dispersion. The fine prisms that were actually employed were of white flint glass of an angle of  $62^\circ$ , worked by Mr. ADAM HILGER. The length of the side of the prism is about  $2\frac{3}{4}$  inches, and the height  $1\frac{3}{4}$ . A motion for setting and keeping the prisms at the angle of minimum deviation for all rays was also made for me by the same optician; the fact that rays of very great comparative wave length were to be examined rendered this all the more necessary. The collimator was 20 inches long, and the focus was adjusted for the lowest visible ray. The slit had jaws, both movable, which could be opened to any required extent by means of a differential screw motion. The lens at first attached to the camera had a focus of 18 inches, but subsequently this was abandoned for a lens of 30 inches focus, and of about 3 inches aperture. A rather imperfect heliostat, but one which sufficiently answered my purpose, was used to cast the beam of light on a condensing lens of 6 feet focus and 5 inches aperture, to form a solar image on the slit. The focusing was rather a matter of guesswork, and trial plates had to be exposed to attain really sharp images in any part of the ultra-red. The rapid alteration in the focus of this portion of the spectrum made it impossible to obtain anything except a narrow strip on which the FRAUNHOFER lines were absolutely sharp, and that only on the portion of the spectrum near A, for at the wave length 10,000 the spectrum became so compressed that any collection of fine absorption lines inevitably appeared as more or less shaded bands. A reflecting mirror was finally adopted in lieu of the camera lens, the position and management of which will be more fully described immediately. The difficulty of focussing was thus mitigated, if not altogether surmounted.

For the photography of the diffraction spectrum the same collimator and camera, with its lens, were used, substituting for the prisms a diffraction grating by RUTHERFURD of about 8600 lines to the inch. A large number of photographs have been taken of the ultra-red end of the spectrum with this apparatus, most of which have proved useless, in consequence of the difficulty in obtaining an accurate focus of the absorption lines. During the past year a different arrangement has been adopted, which is better adapted to the diffraction spectrum.

The following is a sketch of the apparatus as employed :—

A collimator (Plate 30, fig. 1), 8 feet in length, was constructed after my design by Mr. HILGER, and instead of attaching a collimating *lens* to it, a collimating mirror (silver on glass) of about 8 feet focus was substituted.

The slit S is  $1\frac{1}{2}$  inch long, and was mounted at the side of the tube as shown. The beam of light was directed full on to the slit by the heliostat, and passing through the slit falls on M, a plane and adjustable mirror (also silver on glass). It is then reflected down the tube, and falls on A, the concave mirror already referred to, and the rays pass up the tube in a parallel beam.

At B they fall on a reflection grating of 17,600 lines to the inch, and about  $1\frac{3}{4}$  inch in width\*; the dispersed beam falls on another concave mirror, B, of about 3 feet focus, and the image of the spectrum is formed on P, the photographic plate, which is attached to a camera in the usual manner. I may mention that a quartz, and also a rock-salt lens of 8-foot focal length is provided for this collimating tube, the mirror A and slit being movable. The reasons for adopting the long collimator and the mirror may be mentioned here, since at first sight there appears to be but little reason for using them. There is no doubt but that glass absorbs the ultra-red rays to an appreciable extent, and I need only refer to the experiments of Sir WILLIAM HERSCHEL, TYNDALL, LAMANSKY, and others in support of this statement. My primary object was therefore to prevent any serious loss by only allowing the beam of light to traverse as small a thickness of this material as I possibly could. That the rays are not totally absorbed there is proof in the diagram of the prismatic spectrum, which I attach to this communication, the prisms employed being of the glass I have already referred to. By adopting the long collimator the beam of direct light reflected from the heliostat and falling on the grating was a circular patch of about  $\frac{3}{4}$  inch diameter, and this had traversed no glass except any that might be placed in front of the slit. There was but little loss of light, since to give the same definition the slit could be opened five times wider than with the shorter collimator, with which a condensing lens could be employed. There was another reason for adopting the system of reflection in the camera and also in the collimator, viz. : that as the foci for all rays are coincident, by focussing any visible portion of the spectrum of the second order on the plate, and then cutting this off by a suitable medium, the absorption lines in the dark rays beyond the red of the first order would be equally well defined. It will also be seen that by this plan it was possible to obtain a photograph of the second order on the same plate as one of the first order, by covering up the top half of the plate for the one, and the bottom half for the other. This is of prime importance in making a determination of the wave lengths of the invisible portions, and it has been utilised for settling the approximate values which are given in the map appended (Plate 31).

I have no hesitation in recommending that a mirror in the camera should be substituted for the ordinary lens. It gives most excellent definition, and can be used to

\* Ruled by Mr. CHAPMAN, of New York, with Mr. RUTHERFURD'S ruling machine.

bring the invisible rays to a focus with the utmost facility. One great difficulty with which I have had to contend in photographing the diffraction spectrum has been to obtain a proper absorbing medium for the more refrangible end of the spectrum which would be placed in front of the slit without interfering with the invisible rays.

In the prismatic as well as in diffraction spectrum this is of immense importance. With the former the prisms become illuminated with white light, and this causes a veil to appear with the image on the plate when developed, if the exposure be at all prolonged. With the latter, the ultra-red of the first order overlaps the violet, blue, and green of the second order, so that it becomes a necessity to use an absorbing medium unless the different orders are separated by means of a prism: a proceeding which may introduce error in calculating the wave lengths, unless very great precautions are taken.

In experimenting on this subject I employed the prismatic arrangement, and found that stained red and ruby glasses were both serviceable, as by interposing either of them I could obtain photographs of the lowest limit of the prismatic spectrum hitherto obtainable without them. Even when employing a glass cell containing an aqueous solution of potassium chromate, the same limit was reached. The times of exposure, however, differed considerably. Thus to obtain an impression of the ultra-red when the absorbing media were stained red and ruby glasses, the times of exposure were as one to two, and with the chromate half as much as that for the stained red.

The latter was very suitable for photographs of the prismatic spectrum, but did not absorb sufficiently in the green to render it a useful adjunct with the diffraction spectrum.

Messrs. CHANCE, of Birmingham, kindly supplied me with some microscopic glass flashed with ruby, and this has been of great service to me, as it cuts off all rays more refrangible than D. It is this which I have principally used in obtaining the diffraction photographs, though a slightly lower limit is reached when separating the spectra by a rock-salt prism. Recent experiments have shown me that a solution of iodine in carbon disulphide, when placed in a rock-salt cell, may also be employed with advantage, as indicated by TYNDALL.

*Map of the infra-red diffraction solar spectrum.*

In Plate 31 accompanying this paper I have endeavoured to give as accurate a map of the solar spectrum from A, as far as 10,750, as could be consistently obtained from the photographs I have taken with my large grating. A variety of photographs have been taken at different times, and it is by combining the best of these (and when I say the best I mean those which have the greatest definition for particular regions) that the map has the accuracy which I trust it will eventually prove it has. Mr. DE LA RUE kindly placed at my disposal, as often as I required it, the excellent micrometric measuring machine which he had constructed for measuring the series of



photographs of the sun which were taken at Kew. Thanks to Mr. WHIPPLE and his assistants, the arduous task of reading the measurements was materially lightened, which otherwise must have been protracted over a longer time than they have been. The instrument employed measures accurately to the  $\frac{1}{1000}$  of an inch and by estimation to half that quantity; but I may say that this delicacy is rather too great for the photographs, and I can only trust my readings to  $\frac{1}{500}$  of an inch. The magnifying power of the instrument was slightly too great for some of the finer and also for some of the less transparent absorption lines, and in the first measurements some escaped detection. By carefully going over the whole photographs with a less magnifying power the missing lines have been inserted with very fair accuracy; since most of them were situated close to lines which had been previously measured with the higher magnifying power. I believe that the accuracy of position of these inserted lines is but little, if anything, inferior to the remainder of the lines. After the whole of the photographs had been measured they were all reduced to a common scale by taking fiducial lines and interpolating in the usual manner. Except for a few of the last lines shown near wave length 9700, more than one photograph was measured, and the reason why only one photograph was used for this region was that that one employed had far better definition than the others, though all showed the presence of the absorption phenomena.

In regard to the accuracy of reading I cannot do better than quote the measurements of the A group, to show the accordance between two sets of readings.

	Photo. I.	Photo. II.	Reduced to scale.
A <sub>0</sub>	2778·0	2778·0	100·0
A <sub>0</sub>	2824·0	2825·0	131·0
A <sub>0</sub>	2826·5	2827·0	132·5
A <sub>1</sub>	2838·0	2838·0	142·0
A <sub>2</sub>	2846·0	2845·0	147·0
A <sub>3</sub>	2853·0	2853·5	152·0
A <sub>4</sub>	2861·0	2861·5	157·0
A <sub>5</sub>	2870·0	2869·5	163·5
A <sub>6</sub>	2880·0	2879·5	170·0
A <sub>7</sub>	2890·0	2888·5	177·0
A <sub>8</sub>	2900·0	2899·5	184·0
A <sub>9</sub>	2910·0	2910·0	190·5

The scale of the original map is 40 times the original measurement, 1 inch being represented by 40 inches.\* The size of the plates used was 6 inches by  $2\frac{1}{2}$  inches wide, and from A to 10,750 occupies nearly that length.

The slit of the collimator was tolerably narrow, but not quite so closed as is usually the case when photographs of the more refrangible end are taken. Thanks to the

\* For publication the scale has been reduced to 20 times the original measurement.

wide dispersion of the grating, however, the width of the slit had but little bad effect in giving the finest lines sharply defined; in fact, the finest lines are the most sharply defined.

I have already described the sensitive salt employed, so I need not refer to it further except to say that as the photographs were taken in the height of summer and autumn, the most sensitive salt could not be employed.

I have not thought it expedient in the map to give the wave lengths as being absolutely definite; there may be, and probably is, a little uncertainty regarding them at the present time, but I hope at some future date to be able to make a table of absolute wave lengths which can be applied to the map. At any rate, it is believed that there cannot be any great error, since certain of the lines have been compared with the less refrangible end of the next order of the spectrum as photographed on the same plate, as described in the foregoing pages. It is worthy of remark that in this portion of the spectrum we come to a locality in which it is continuous. At first sight this seemed inexplicable, and many endeavours were made to obtain photographs of such definition as to show absorption lines of some description. I have not succeeded in so doing, nor do I believe that they are to be found, except they be of the very finest description; in fact, much finer than any I have met with below A. In this conclusion I am borne out by a reference to the prismatic spectrum of this portion, in which the same locality exhibits a perfect blank as regards absorption. From smaller photographs taken with the grating I believe it will be found that this region extends beyond wave length 12,000. It might be thought expedient that a reference should be made to the bands of lines which are due to atmospheric absorption. All that can be said is that, whether at a high altitude or a low one, the same intensities of lines exist, except, perhaps, in one or two cases which are very far from being well marked. I have therefore preferred to give all the lines present, leaving a discussion as to what they may be due to a subsequent paper.

Of one thing, however, certainty may be expressed, viz.: that all rays will pass through several inches of glass and through half-an-inch of water; the absorption due to both these substances is evidently one gradually increasing as the wave length increases. I was not at all prepared to find that these long waves could traverse anything like the thickness of either one that they did without being affected. In some cases plates were absolutely exposed whilst immersed in an aqueous solution of potassium nitrite to prevent oxidation of the image, which can be caused by excess of light, as I have already shown in previous communications to the Royal Society, and still a low limit has been obtained. Regarding the time of exposure of the plates for the diffraction spectrum there is much variation; on a bright spring day the same action takes place in 10 minutes which in autumn takes half-an-hour to effect. I have found that when the A line was well visible with ruby glass in front of the slit a short exposure could be given. With the prismatic spectrum five minutes is sufficient exposure

where four or five prisms of flint glass are used and the slit very narrow, the focal length of the mirror being about 30 inches.

*Map of the infra-red prismatic solar spectrum.*

Plate 30, fig. 2, is a drawing from a photograph of the prismatic spectrum,\* showing bands of absorption, but which resolve themselves into lines when the diffraction grating is used. Excepting the bands A, Z, and X, these bands at first are somewhat difficult to recognise in the diffraction spectrum, but by using an artifice they are at once distinguished. If the diffraction photograph be held obliquely from the eye in such a manner that the lines appear to blend one into the other, we have the same appearance of bands as in the prismatic spectrum.† In my paper originally sent in to the Royal Society a remark was incidentally made that the limit of this spectrum was apparently reached; but Professor STOKES pointed out that the supposition was incorrect, as by setting up a curve of  $\frac{1}{\lambda^2}$  and producing it, there could be but little doubt that the theoretical limit lay beyond the boundary of the photograph. In the diagram‡ this latter curve has been drawn, and also a curve showing absolute wave lengths.

LAMANSKY'S *thermograph*.

In December, 1871, LAMANSKY published in the 'Monatsberichte der Königl. Akademie der Wissenschaften zu Berlin,' a communication on the heat spectrum of the sun and the lime light, to the original of which I have not had access, but have used a translation which appears in the Philosophical Magazine for April, 1872. LAMANSKY'S thermograph was made by aid of a thermopile, the deflections being a measure of the heating effect on lamp-black of the various parts of the spectrum. In some cases he used a flint-glass prism with which to obtain his spectrum, in others he used a rock-salt prism, and it is from the results with the latter that his diagram is constructed. In making a comparison of this thermograph§ with the photograph of the prismatic spectrum I have had recourse to the method of graphically setting up ordinates  $=\frac{1}{\lambda^2}$  on the diagram.||

\* The bands  $\psi$ ,  $\psi$ , were marked from photographs taken on March 25, 1880, a note to that effect having been sent to the Secretary of the Royal Society June 10, 1880.

† Photographs taken with a wide slit also give the same effect.

‡ The amended diagram and description was communicated to the Royal Society January 8, 1880.

§ The first comparison was withdrawn from the paper, owing to the construction of a new diagram showing the curve of wave-lengths and  $\frac{1}{\lambda^2}$  as suggested by Professor STOKES.

|| In the copy of LAMANSKY'S diagram in the Philosophical Magazine there is evidently an error, in that the ordinate of the last maximum cuts the descending curve. This has been corrected.

Taking G, F, E, and D as fiducial points as given by LAMANSKY, it was found that the lines joining them lay nearly in a straight line, with the exception of that joining F and G. The lines F, E, and D were taken as correct, and the straight line on which those points most nearly lay was prolonged to meet the line on which the abscissæ were measured. The various bands and lines of absorption in the ultra-red portion of the spectrum, as shown by the photograph, were inserted. It will be seen (Plate-32, fig. 1) that the thermal minima agree with  $z$ ,  $\pi$ , and  $\tau$ , and the maxima with X,  $\sigma$ , and  $\phi$ , positions which would be naturally assumed as most probable. There cannot be much doubt as to the correctness of this view, if a reference be made to a passage in LAMANSKY'S paper. He says: "These three breaks or bands are not of equal breadth; the first is much more sharply separated from the second than the second from the third. It may easily happen if the movement of the thermo apparatus be not sufficiently delicate that the *second and third appear as one common break.*" A glance at the diagram will show that this is most probable;  $\pi$ ,  $\sigma$ , and  $\tau$  *would* easily blend into one. LAMANSKY asks the question, "Is not the limit of refraction situated at the place where the heat effect of the solar spectrum attains its last maximum?" If the positions assigned to these maxima by myself be correct it is evident that it has not been attained. From a careful perusal of Sir JOHN HERSCHEL'S memoir, which is to be referred to, it would seem that the maxima show themselves by his method with greater difficulty the nearer they approach the limit of refraction.

#### HERSCHEL'S *thermograph*.

In the Philosophical Transactions for 1840 is to be found the thermograph of the prismatic spectrum as delineated by Sir JOHN HERSCHEL. The thermograph itself was made by causing an image of the solar disc to focus itself on a sheet of blackened tissue paper moistened with alcohol, after passing through a flint or other prism; the drying of the alcohol in some parts more rapidly than in others gave a figure such as shown in Plate 32, fig. 4, demonstrating that the heating effect of the spectrum was discontinuous. Figs. 3, 4, and 5 are taken from Sir JOHN HERSCHEL'S paper, and it should be noted that these are the images obtained by the sun's whole disc, whilst the photograph was taken with a narrow slit.

Lord RAYLEIGH gives an account of a repetition\* of HERSCHEL'S experiments, and finds that the thermographs he obtained are not comparable with HERSCHEL'S, the maxima of heating effect lying in very different positions; he also indicated that the spot  $\epsilon$ , and probably  $\delta$ , lay beyond the theoretical limit of the prismatic spectrum. In some of my own experiments with the same method I found that I obtained thermographs which were very similar to those of HERSCHEL with the exception of the spot  $\epsilon$ —a spot, it may be remarked, the existence of which Sir JOHN HERSCHEL himself did not absolutely insist upon. I have tried to examine the latter's thermograph with

\* Phil. Mag., vol. iv. (fifth series).

due regard to my own experiments, and own to meeting serious difficulties. It can hardly be possible to doubt the accuracy of the measures made by HERSHEY, but it must be remembered that the length of spectrum with which he worked was very small, 4 inches being the extreme limit of the thermograph, whilst not 2 inches was the length of the visible spectrum. It must also be recollected that he fixed the position of the various parts of his thermograph by a reference to the absorption spectrum of a solar image through cobalt glass, using the centre of the yellow solar image so obtained as a starting point for his measurements. It is to this that I wish to draw special attention as being the cause of the probable difficulty in recognising the breaks in the continuity of the heating effect of solar radiation when examined by the aid of a prism.

We may assume that the upper limit of visibility of the spectrum lies somewhere near H, and if, as is shown in the figure (Plate 32, fig. 2), we deduct the semi-diameter of the sun from the place shown as the limit of visibility, we have a very probable position for the H line. Now in the plate accompanying his paper (Philosophical Transactions, 1840) HERSHEY shows a photographic spectrum taken on what he calls bromuretted paper. Having experimented on similar paper, I found that the lowest part of the spectrum reached by his method of working was near X (Plate 30, fig. 2).

Again, a measurement of the position of the lithium and sodium lines in regard to the position of the red images of the sun seen through cobalt glass (Plate 32, fig. 4) places the centre of it near the line B.

Taking H, B, and X on HERSHEY'S scale of lengths as fixed by this discussion, and setting up as ordinates  $\frac{1}{\lambda^2}$ , we find that the lines joining them lie nearly in a straight line, but that the fiducial line through the centre of the yellow solar image (Plate 32, fig. 4)\* lies nearer to D than it should do. This point should be nearly half way between D and E, but slightly near D. The difference between the position given it by this graphic way, and that it should occupy according to HERSHEY'S drawing, is  $\frac{1}{15}$  of an inch—a length which is certainly very small. If the bands and lines shown in the photograph are inserted by means of their  $\frac{1}{\lambda^2}$  ordinates, it will be seen that the breaks of continuity in the thermograph agree fairly well with the absorption as shown in the photograph on the same plate. I have shown in chain dotted lines the approximate positions that H, E, D, B, A, X,  $\tau$ ,  $\phi$ , and  $\psi$  would occupy when the position of the spectrum is fixed by reference to images of the sun seen through the cobalt glass as given in the diagram. It will be noticed that there is still an agreement in the main between the thermograph and the photograph, but (first) that the upper limit of visibility is a long way in the ultra-violet, and (second) that  $\delta$  and  $\epsilon$  of the thermograph are beyond the theoretical limit of the spectrum. This last can scarcely be the proper

\* Figs. 3, 4, and 5 are taken from Sir J. HERSHEY'S plate in the Phil. Trans., 1840.

comparison of the thermograph with the photograph, and I am inclined to believe that the first method gives a result which should be fairly accurate though it omits  $\epsilon$  from the thermograph.

If H be taken as known, and if the fiducial line  $\gamma \gamma$  be correct, the limit of the spectrum would be beyond  $\epsilon$ ; but it is hard to reconcile this with the fact that the centre of the last red image of the sun seen through cobalt glass would be near C, otherwise the absorptions shown in the photograph would agree with the breaks of continuity in the thermograph.

*Theoretical deductions.*

It has seemed advisable to keep any theoretical deductions to the concluding portion of this paper, as the first portion contains wholly facts on which no controversy, I can imagine, can arise; at the same time, it would be wanting in candour did I not point out what seems to me to be some evident conclusions which can be drawn from the experiments that I have made over such a long period.

I have pointed out that the form of silver bromide which is sensitive to the red and ultra-red of the spectrum transmits the least refrangible rays to a marked extent, but it does not do so entirely; in fact, we may say it absorbs all rays, the less refrangible the best, the more refrangible much less, and the green rays least of all. A very instructive experiment to repeat is to photograph the spectrum of burning coal-gas with this salt. It will be found that the curve of intensity constructed as already indicated has the following appearance in the prismatic spectrum.

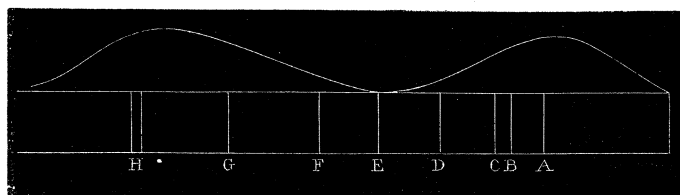

It shows two well-defined maxima, which are situated somewhere about wave lengths 3800 and 7600. It may be merely fortuitous that these occupy the positions they do in the spectrum; but if we are to look at the occurrence of the maxima at intervals, one of which has double the wave length of the other, we cannot but be struck with the idea that a molecule of the silver bromide is responding to harmonic vibrations. In the state in which the silver bromide has only one maximum at about wave length 3800 it seems probable that the molecule exists of only half the weight. The heavier molecule may be well supposed to take up those vibrations which we may say are an octave higher, whilst it would not at all follow that the lighter molecule would respond to the vibrations of the lower octave.

The blue transmitting form of silver bromide can readily be transformed into the red transmitting form by simple friction, in which state it becomes as insensitive to the lower octave as if the molecule had been formed by chemical means, as by the ordinary methods of preparation. A difference in molecular state for other compound bodies has been suspected by Mr. J. NORMAN LOCKYER,\* and this existence of two states of silver bromide lends confirmation to his view.

I have to thank the Astronomer Royal for kindly placing diffraction gratings at my disposal, as also Dr. J. W. DRAPER and Professor LANGLEY for procuring me others, with which the most successful part of my work has been carried out. My assistant, Corporal JACKSON, R.E., has been most invaluable to me in making the various emulsions under my directions and in taking negatives when my official duties prevented me from personally utilising what little sun we have had during the last summer and autumn. To Mr. DICK my acknowledgments are also due for the care he has taken in preparing the map of the diffraction solar spectrum.

\* Proc. R. S., note 11, page 153, 1874.—‘Studies in Spectrum Analyses,’ page 120.

F to b = 30.0	$\frac{1}{\lambda^2}$	F = 424
b to E = 6.8		b = 375
E to D = 39.7		E = 360
D to C = 29.8		D = 288
C to B = 10.5		C = 232
B to A = 18.7		B = 212
A to Z = 13.12		A = 173
" " X = 18.75		Z = 147
" " $\pi$ = 26.70		X = 137
" " $\rho$ = 30.75		$\pi$ = 122
" " $\sigma$ = 31.50		$\rho$ = 113
" " $\tau_1$ = 35.90		$\tau_1$ = 105
" " $\tau_2$ = 36.20		$\tau_2$ = 103.5
" " $\phi$ = 53.50		
" " $\phi$ = 55.50		
" " $\psi_1$ = 66.5		
" " $\psi_2$ = 68.5		

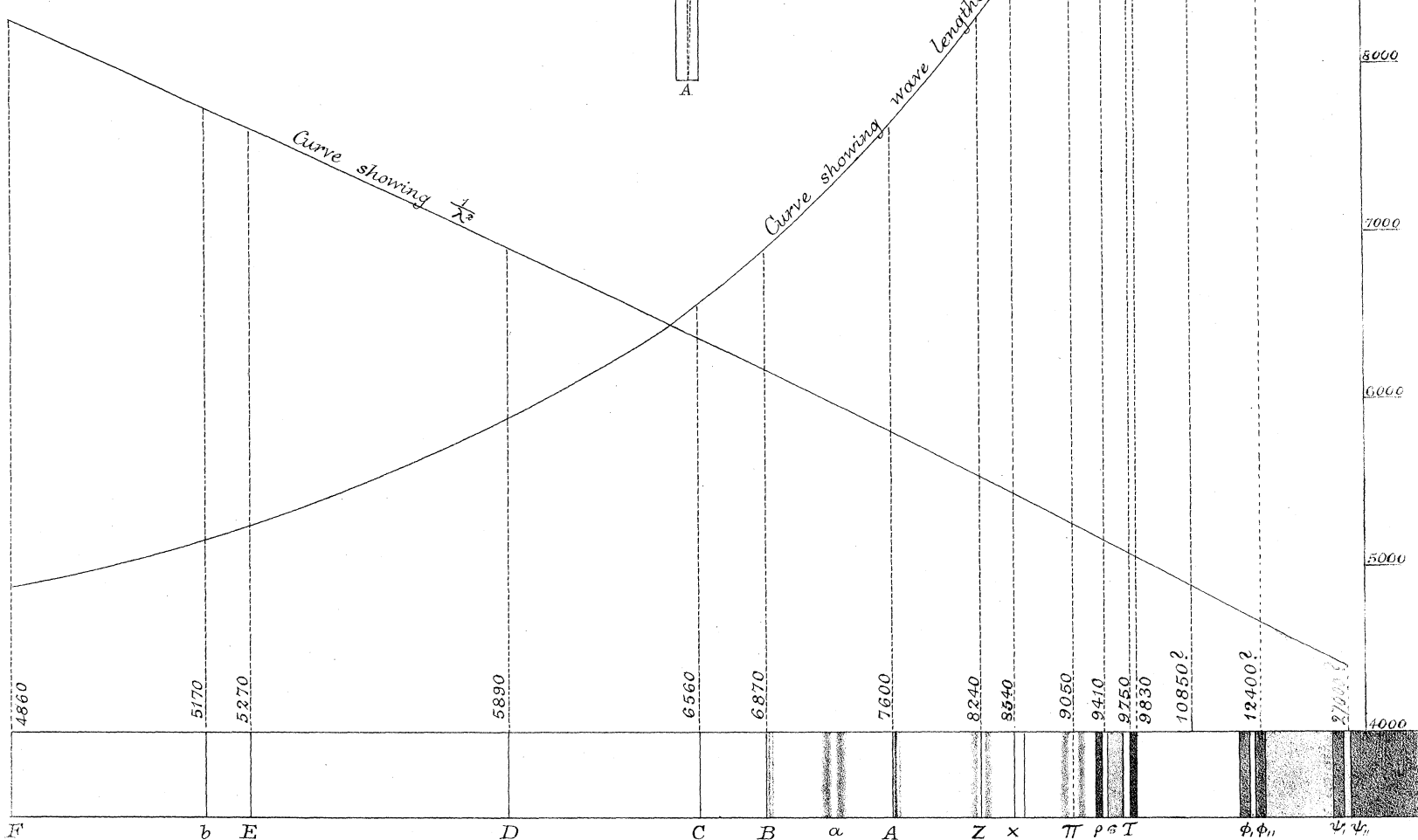
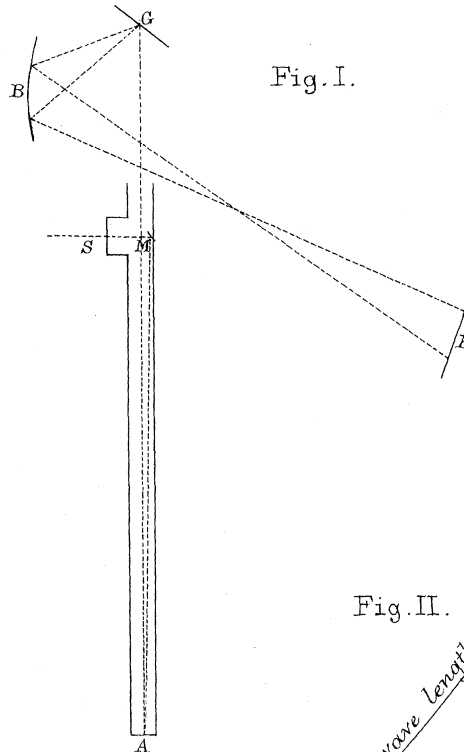

Prismatic Solar Spectrum,  
measured from a Photograph.



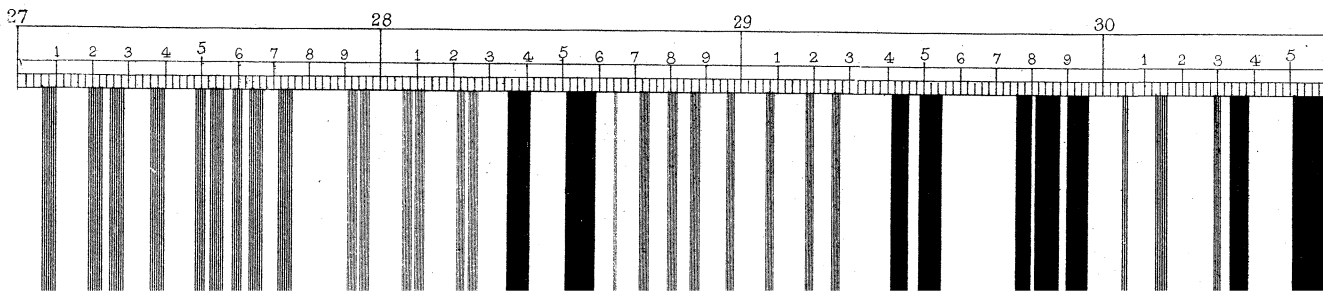
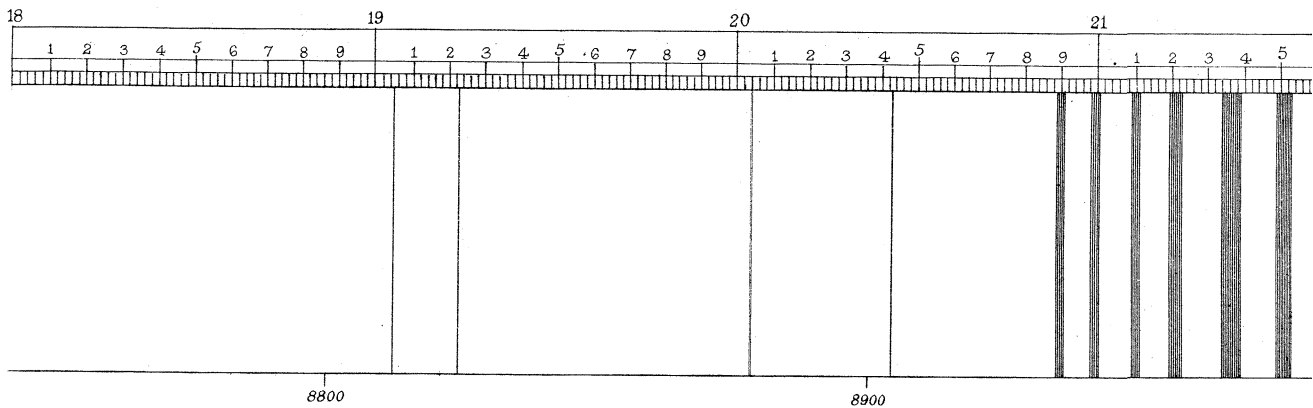
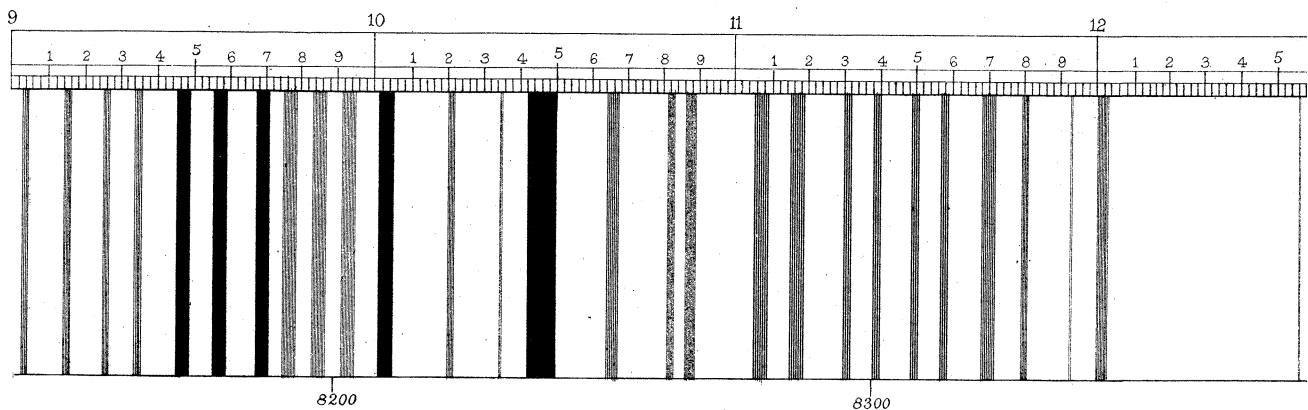
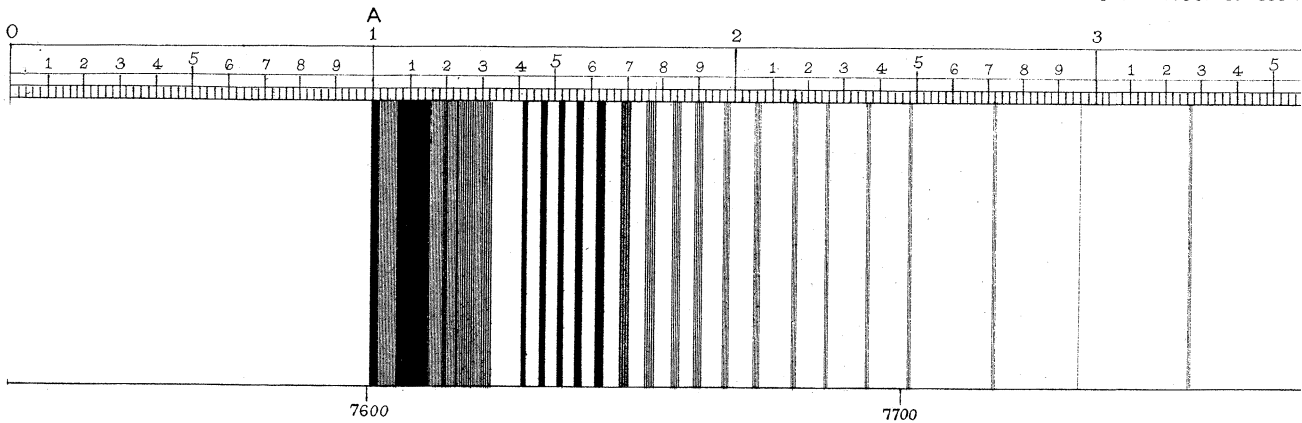

THE INFRA-RED END OF THE SOLAR SPECTRUM.

Measured from Photographs taken by the aid of Diffraction Gratings.

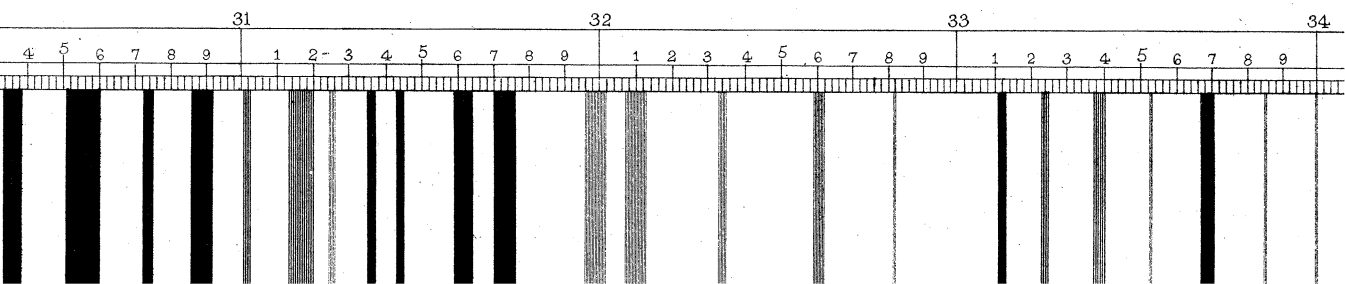
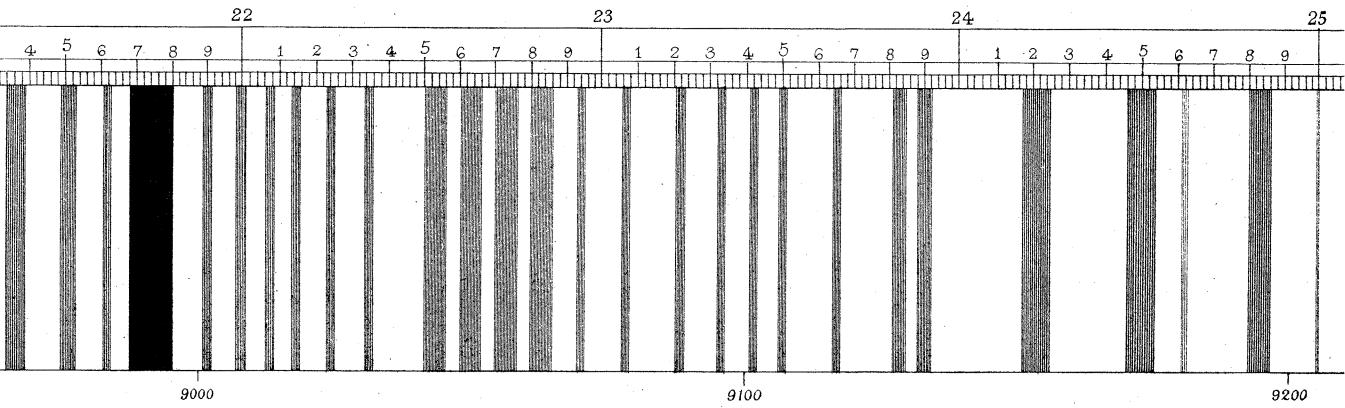
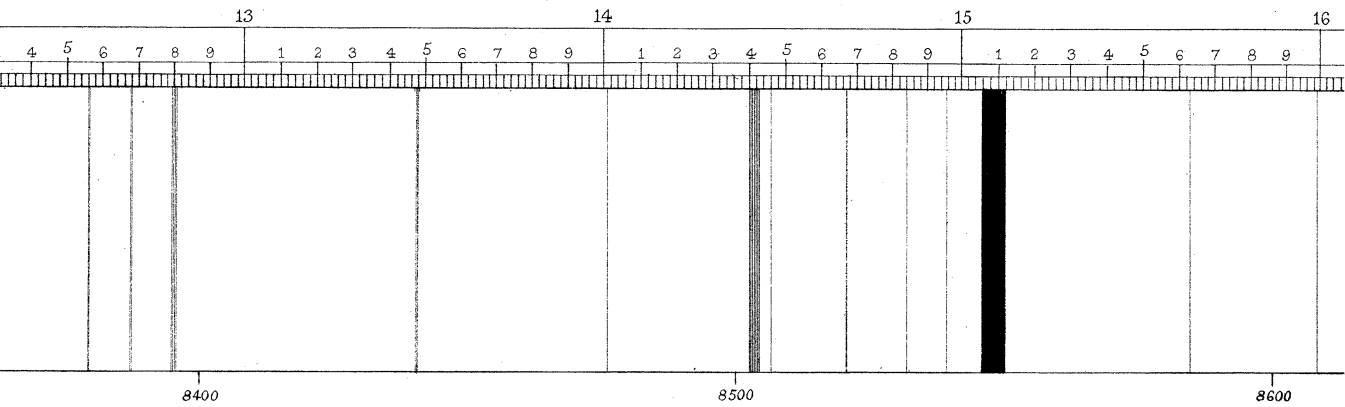
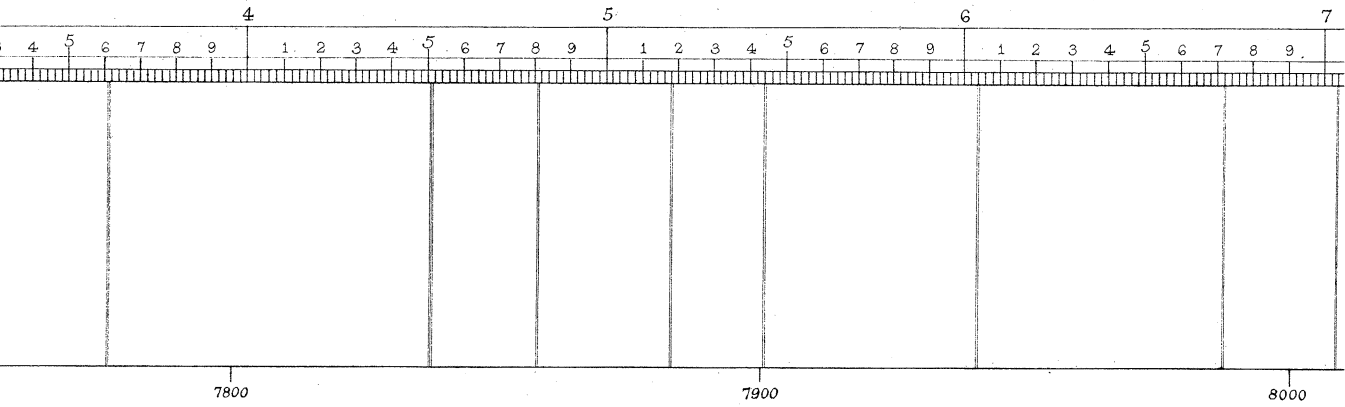

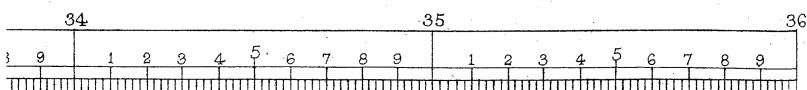
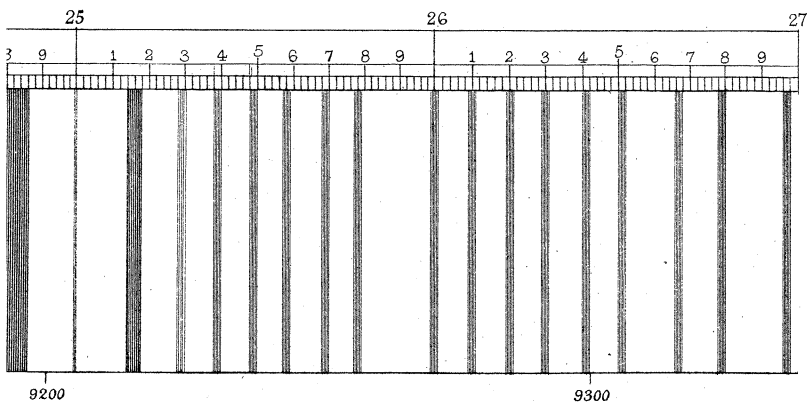
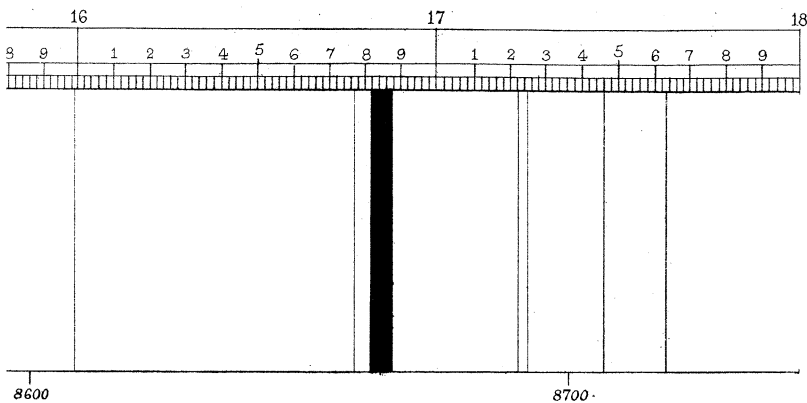
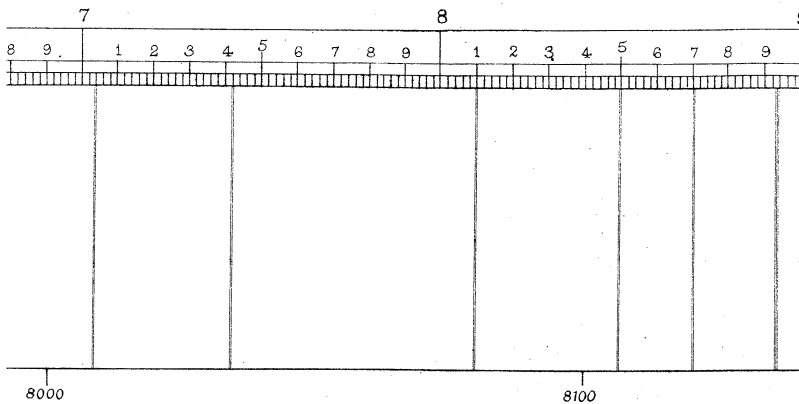

*At this point there is a continuous spectrum extending as far as wave length 10750 at which point the diffraction Photographs end, but the Photographs of the prismatic spectrum*

Whiteman & Boss

9400

9500

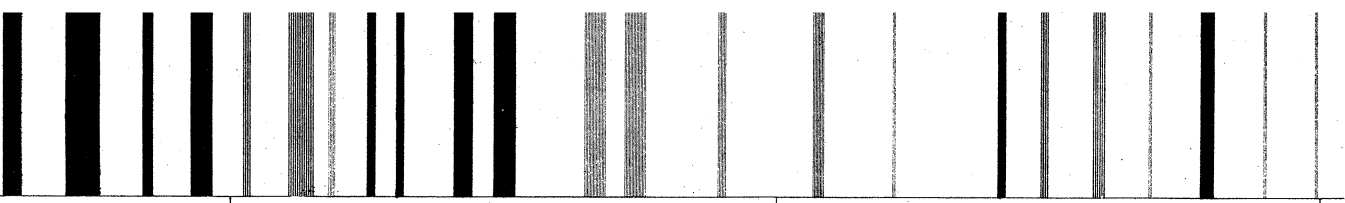

9600

9700

9800

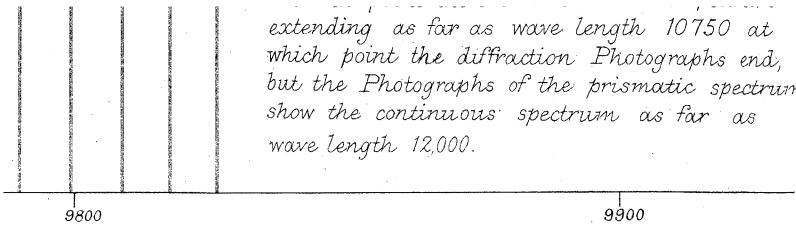

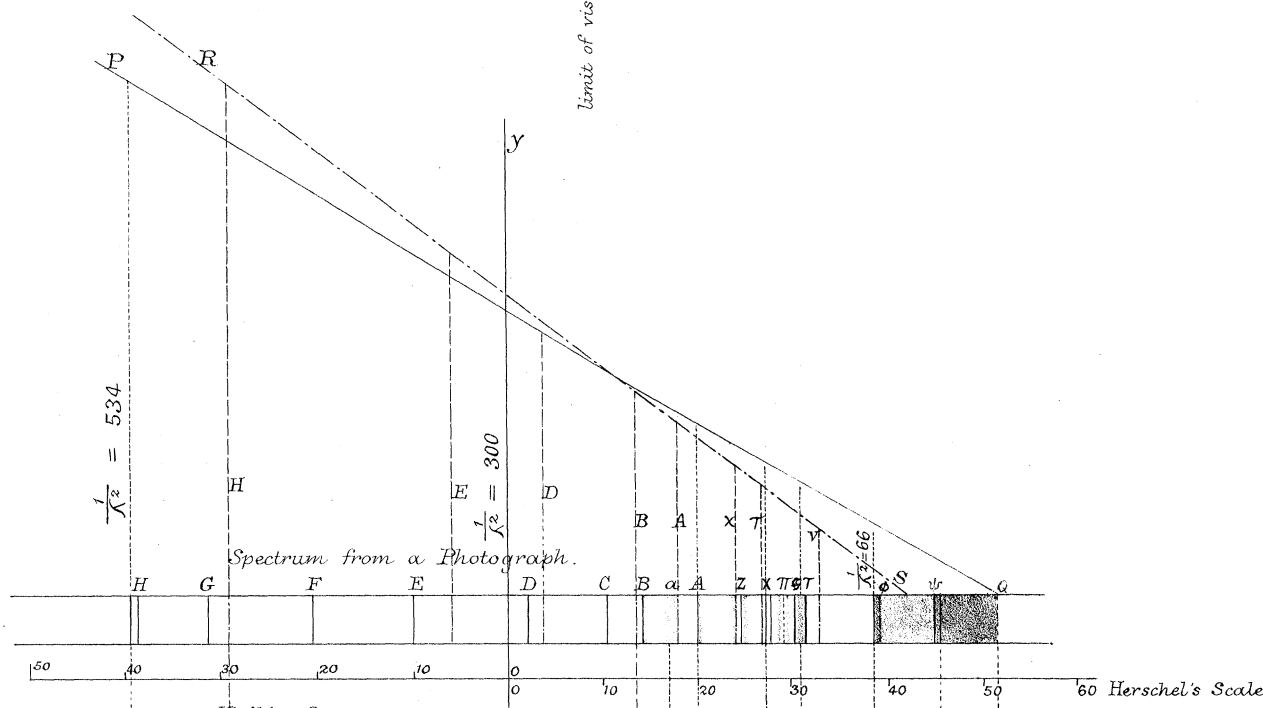
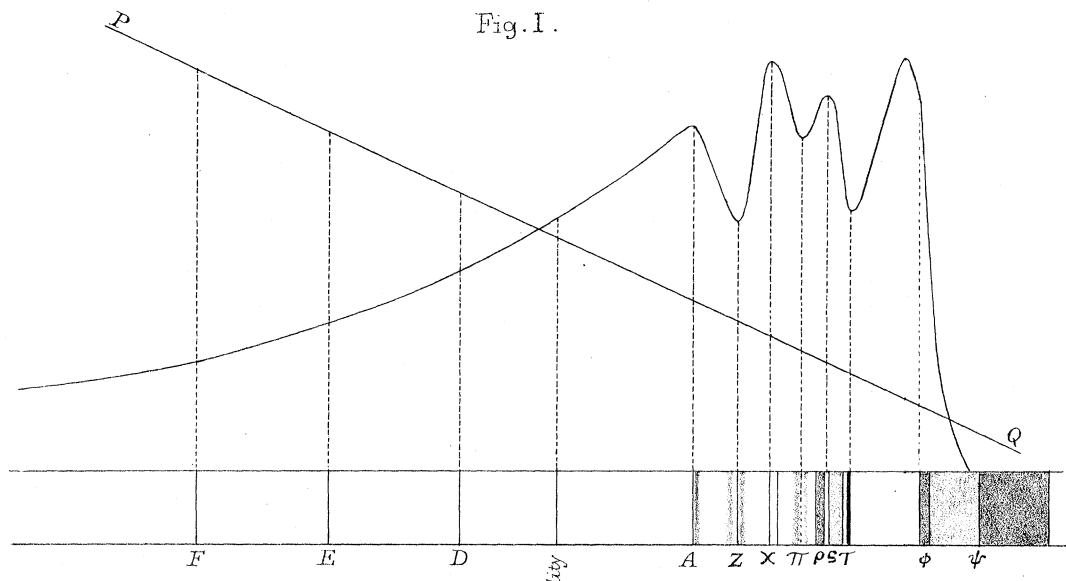

Fig. III.



Fig. IV.



Fig. V.

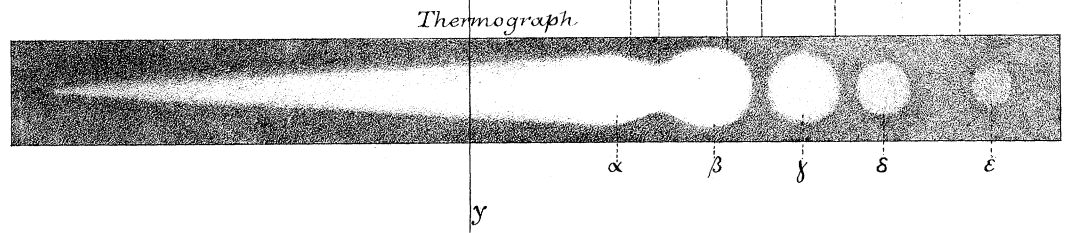

As measured from Photographs taken by the aid of Diffraction Gratings.

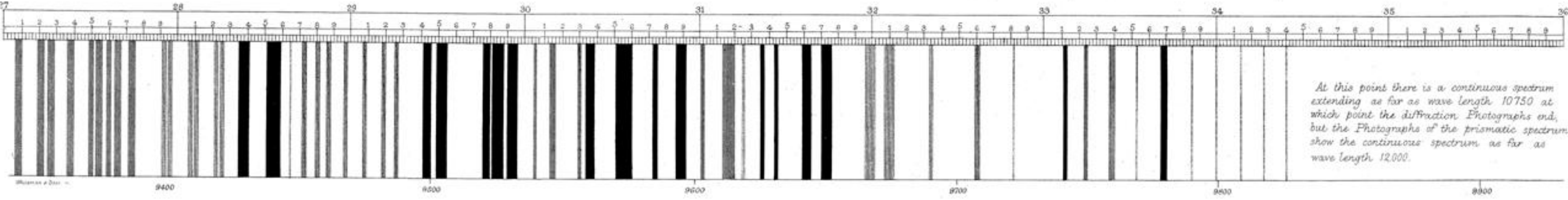
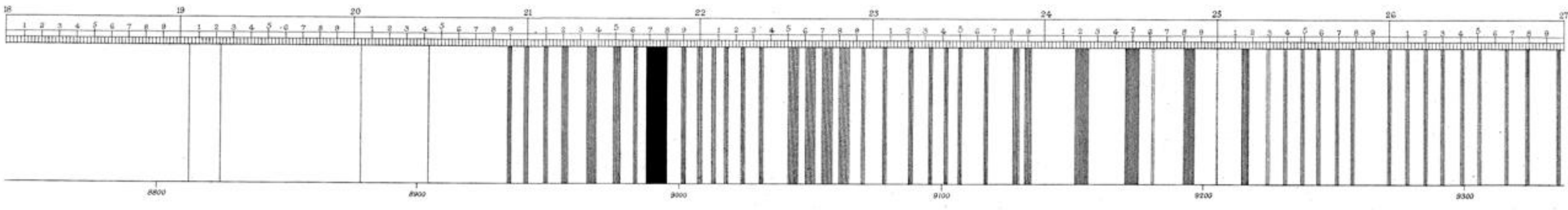
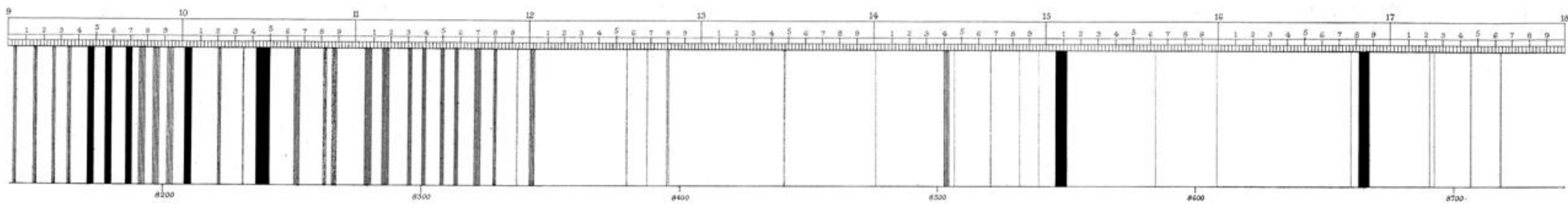
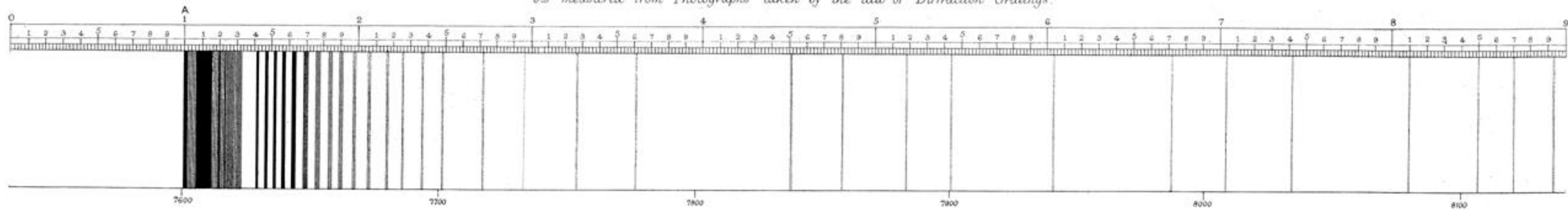

*At this point there is a continuous spectrum extending as far as wave length 10750 at which point the diffraction Photographs end, but the Photographs of the prismatic spectrum show the continuous spectrum as far as wave length 12000.*